

700 EASY



Characteristics



- A Refrigeration unit**
Sparblock plug-in - monobloc ventilated system
- E Insulation thickness**
60mm - HFO polyurethane (no CFC, no HCFC)
- F Internal finish**
AISI 304 stainless steel
- J Floor support**
Stainless steel feet, galvanised external bottom panel
- K Rounded corners/removable parts**
For easy cleaning
- O Worktop**
AISI 304

- Q Interchangeable doors and drawers**

Technical drawing and set-up

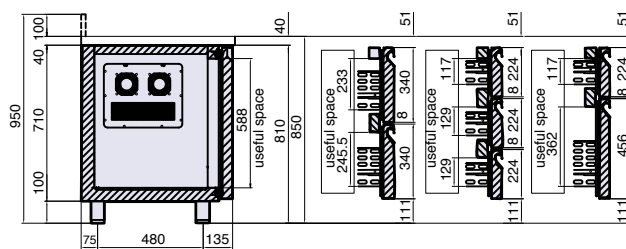
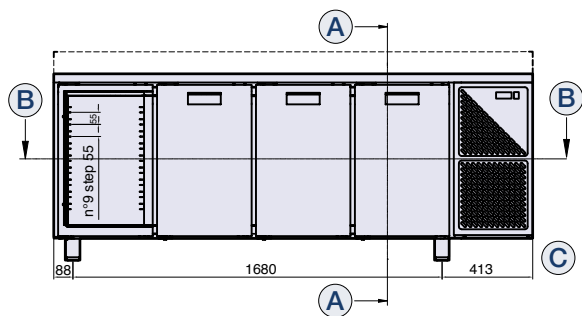

A-A

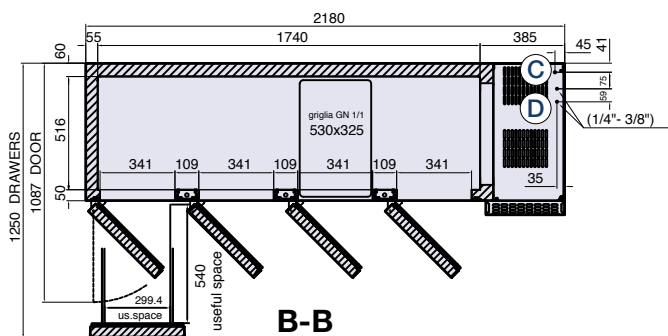

B-B

A Section plane

B Section plane

C Power cable outlet (length 2 m)



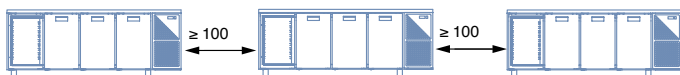

WARNING! While installing, have a qualified electrician connect it to an electrical panel.

D Gas pipes outlet

Prepared for remote motor



Technical specifications

Temperature (°C)	 0/+10	 0/+10
Model	PECT704	PECT704MR
Doors		
Dimensions (mm) L x D x H	2180 x 700 x 850-900	2180 x 700 x 850-900
Packaging (mm) L x D x H	2220 x 730 x 1100	2220 x 730 x 1100
Refrigerant	 R134a	 R134a
Absorption (W)	318	30
Voltage (V-Hz)	230-1 50/60Hz	230-1 50/60Hz
Net weight (kg)	140	126
Gross weight (kg)	160	146